

ILLUMINATOR SR

Outdoor-Rated Emergency Lighting Inverter System



SINGLE PHASE SYSTEMS

875VA/W to 1750VA/W

Uninterruptible Power System



The Myers EPS Illuminator Series SR is a single-phase emergency lighting inverter rated for outdoor use.

The inverter transfers to emergency mode within two milliseconds when utility power is lost, enabling the system to support all types of lighting loads, including HID.

Available in two sizes, the SR can mounted to a pole or on the ground.

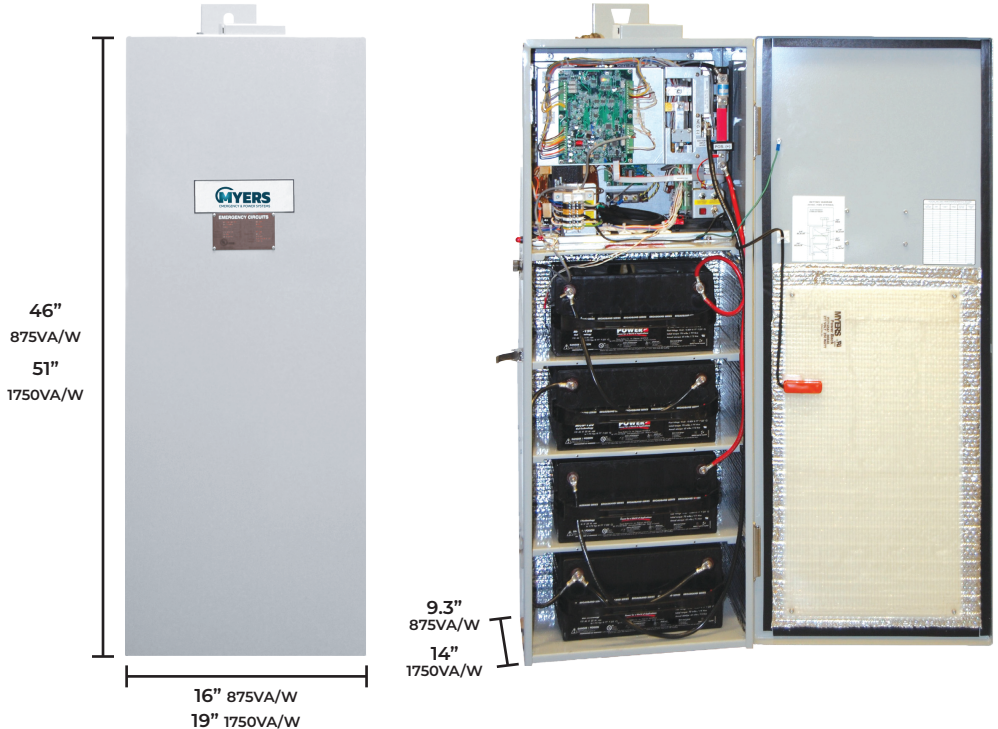

STANDARD FEATURES

- 98% Efficient (Typical)
- UL 924 Listed
- 65 KAIC Input Rating
- Pole Mount and Optional Pad Mount
- Compatible With All Lighting Loads Including HID / LED
- NEMA 3R Rated Enclosure
- No Break 2ms Transfer Time
- 90 Minute Run Time
- Input Circuit Breaker
- Control Panel For Self-Testing And Diagnostics (Optional)

OPTIONAL FEATURES

- Remote Keypad / Display Panel for Self-Testing & Diagnostics
- Heater for Enhanced Performance at Cold Temperatures

SPECIFICATIONS

- Input 120, 208, 240, 277, or 480 VAC 1-Phase 2-Wire
- Input Voltage Harmonic Distortion < 10%
- Output 120 Or 277 VAC 1-Phase 2-Wire
- Output Voltage Harmonic Distortion < 3%
- Output Load Power Factor .5 Lag To .5 Lead
- Compatible With All LED Drivers
- Standard Operating Temperature 32° To 122°F (0° To 50°C)
- Optional Emergency Load Enable
- Optional Operating Temperature to -4°F (-20°C)
- Compatible With Generators
- Status Lights: Normal, Battery Backup, and Fault
- Line Interactive PWM Inverter Utilizing MOSFET Technology
- Forced Air Cooling and Temperature Controlled Fan
- Optional Heater for Enhanced Performance at Cold Temperatures

ILLUMINATOR SR

Outdoor-Rated Emergency Lighting Inverter
Single Phase Systems 875VA/W to 1750VA/W



ORDERING GUIDE

EXAMPLE MODEL # 1-SR-2-S-E(120)-2YW

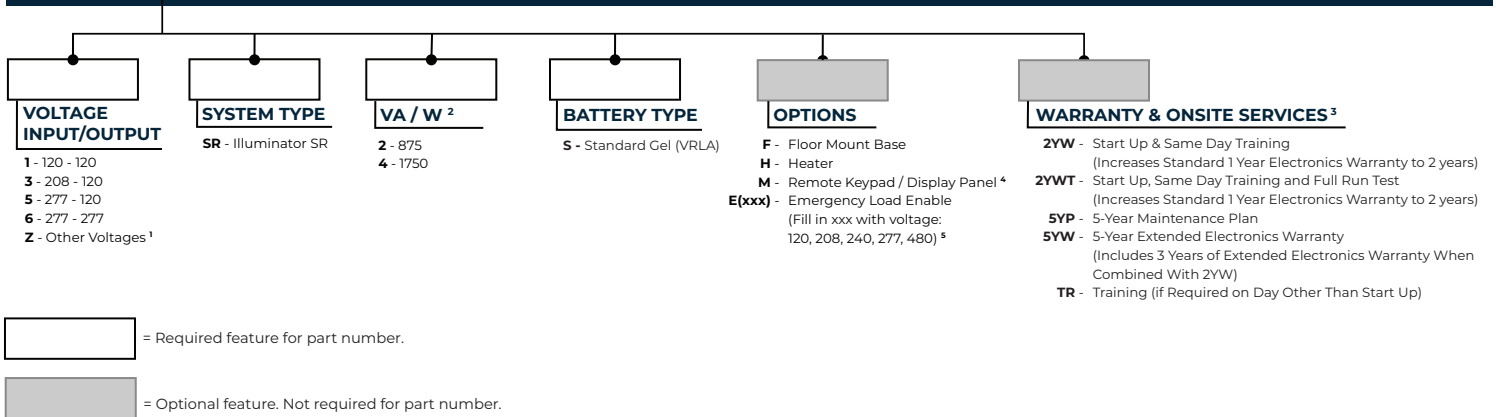

- Only single phase voltages available. Other voltages may require UL testing, consult factory.
- VA= W
- One year electronics warranty is standard
- Used for system setup and status. One recommended per site. 12-foot cord provided.
- Fill in applicable voltage. If voltage is not specified, voltage is assumed to match system input voltage. Option provides the ability to enable emergency output for typically unoccupied venues only when emergency egress is required; i.e. outdoor stadiums.

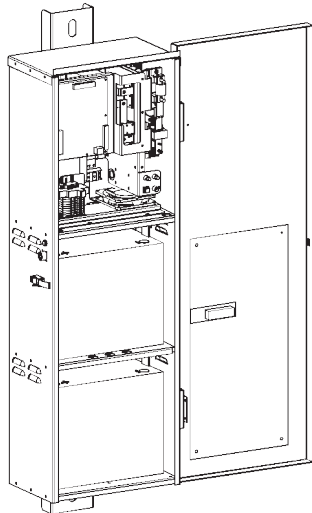

Illuminator SR 875VA/W

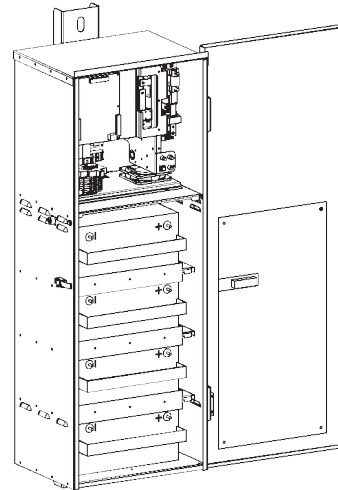

Illuminator SR 875VA/W

DIMENSIONS

Electronics Module							Batteries 90 Minutes @ Full Load				Total System	
Power Rating (VA / W)	Efficiency at Full Load (Typical)	Audible Noise (dBA @ 1m)	Cabinet Dimensions				Total Battery Weight (lbs / kg)	Number of Batteries	Voltage (VDC)	Current (Amps)	Run Time (Mins)	Weight (lbs / kg)
			Width (in / cm)	Height (in / cm)	Depth (in / cm)	Weight (lbs / kg)						
875	98	45	16.0 / 40.6	46.1 / 117.1	9.3 / 23.6	232 / 105	158 / 72	2	24	44	90	390 / 177
1750	98	45	19.0 / 48.3	50.75 / 128.9	14.375 / 36.5	280 / 127	316 / 144	4	24	88	90	596 / 271