

ILLUMINATOR LVM

Emergency Inverter Series



SMARTER, STRONGER, SMALLER

Single Phase Systems 125W and 250W

Myers E&PS now offers the second generation of the LVM Series, with the LVM 125W and 250W.

The LVM 125W & 250W offer power increases of more than 10% while sizing shrinks by more than 65% in volume and 40% in weight. Automatic 0-10V Dimming comes standard and allows larger outputs to be supported safely. These systems support all lamp sources, including LED.

LVM 125W Unit (Standard Wall/Flush Mount)

Scaled Comparison

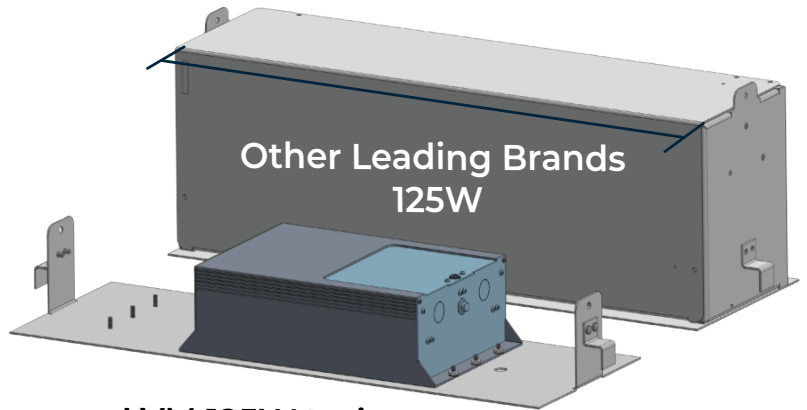

UL 924 | CSA C22.2 No.141-15

LVM 125W Unit
(Grid Mount)

FEATURES

SMARTER



- **Automatic Voltage Detection** eliminates field wiring error
- **Automatic Bypass** overrides local switching and dimming controls
- **Automatic 0-10V Dimming** allows larger outputs to be supported safely
- **Automatic Monthly Testing** eliminates manual monthly testing demands

STRONGER



- A **power increase of over 10%*** with a minimum run time of 90 minutes
- **LiFePO4 Battery Chemistry** for safer, lighter & longer lasting batteries
- **Robust Temperature Range** (0-50° C); operates at 50/60 Hz
- **Plenum Rated**

SMALLER

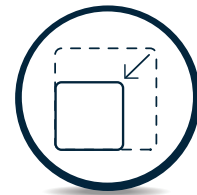

- **More than 65% Decreased Volume***
- **Over 40% Decreased Weight***
- **Advanced High Frequency design** is highly efficient and compact

ILLUMINATOR LVM

Emergency Lighting Series

Single Phase Systems 125W and 250W



ORDERING GUIDE EXAMPLE MODEL # LVM-125-W

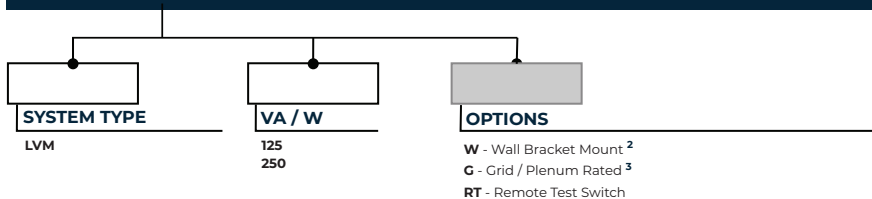

| |
|-------------|
| Type |
| Date |
| Catalog # |
| Project |
| Prepared by |
| Comments |

1. See Mounting Guide for more in-depth descriptions of mounting options.
2. Provides additional mounting bracket that allows unit to be mounted on 16" centers if required.
3. Provides additional mounting bracket that allows unit to be mounted in ceiling grid.

SPECIFICATIONS

| VOLTAGE | | OUTPUT POWER | | WARRANTY | |
|------------|------------|--------------|---------|-----------------|---------------------------------|
| INPUT* | OUTPUT | LVM 125 | LVM 250 | ELECTRONICS | BATTERY |
| 120V, 60Hz | 120V, 60Hz | 125W | 250W | 3 Year Standard | 10 Year Prorated 2 Year Full |
| 230V, 50Hz | 230V, 50Hz | | | | |
| 277V, 60Hz | 277V, 60Hz | | | | |

DIMENSIONS

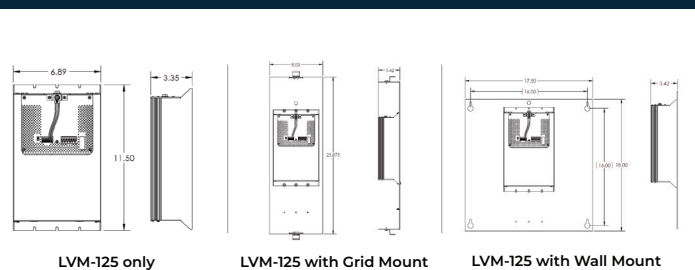

| | Model # | Height (in) | Width (in) | Depth (in) | Weight (lbs) |
|---------------|---------|-------------|------------|------------|--------------|
| Inverter Only | LVM 125 | 11.50 | 6.86 | 3.35 | 9.24 |
| w/Grid Mount* | LVM 125 | 23.875 | 8.00 | 3.42 | 13.64 |
| w/Wall Mount* | LVM 125 | 18.00 | 17.50 | 3.42 | 15.99 |

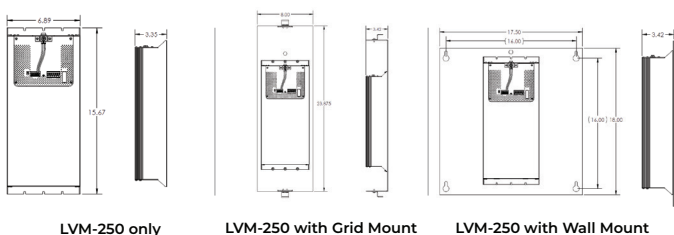

| | Model # | Height (in) | Width (in) | Depth (in) | Weight (lbs) |
|---------------|---------|-------------|------------|------------|--------------|
| Inverter Only | LVM 250 | 15.67 | 6.86 | 3.35 | 15.40 |
| w/Grid Mount* | LVM 250 | 23.875 | 8.00 | 3.42 | 19.80 |
| w/Wall Mount* | LVM 250 | 18.00 | 17.50 | 3.42 | 22.15 |

WIRING DIAGRAM

0-10V DIMMABLE SYSTEM

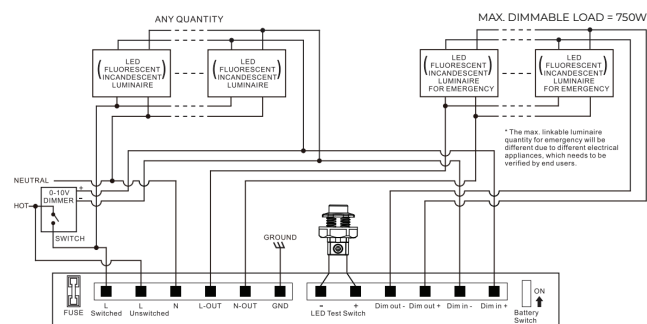

NON - DIMMABLE SYSTEM

